

evoX TECH

Perfect Welds, No Compromises

Upgraded version of the Evo X, already an industry benchmark, the Evo X Tech laser welder sets new standards in precious metal welding.

Featuring **SoftSpot technology** and an **optimized working cycle**, it delivers outstanding performance and operational efficiency. With a **maximum energy of 250 J** and a **peak power of 10 kW**, it ensures superior weld quality on **platinum, white gold, and silver**.



ENHANCED PERFORMANCE

With an **enhanced cooling system**, Evo X Tech can sustain a **continuous working cycle** while upholding the highest standards of welding quality.



SMOOTH AND CONSISTENT WELDING

With the SoftSpot technology, Evo X Tech can achieve **clean and spatter-free welds even on reflective materials** thanks to soft, adjustable and uniform shots.



ENHANCED INTERFACE

The **EnergyTune** feature **automatically adjusts pulse power and duration** based on the **selected spot size and metal**. **Standard programs can be customized** and saved, and are automatically applied when the spot is selected, streamlining the workflow.

Performance and quality

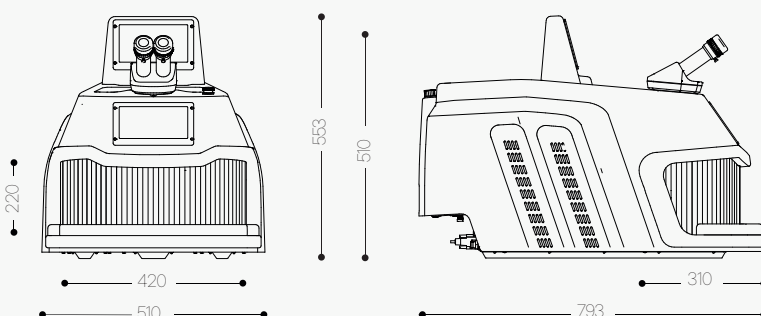

*dimensions in mm

 PATENT PENDING

Discover all our machines, stay connected!



REQUEST A QUOTE

sales@orotig.com

more information on orotig.com

FEATURES



MADE IN ITALY

Leica microscope

Leica 45° stereo microscope with 10x optical zoom and right-eye crosshair.

IUVAPS™ sanitizing system

Constant sanitisation of the environment thanks to the patented IUVAPS™ system, which eliminates dust and pathogens.

Wide welding chamber with adjustable LED

Large welding chamber with a usable volume of 27.2 l, ensuring operator comfort and efficiency. Features an adjustable LED lighting system to facilitate welding on reflective metals.



Intuitive interface

7" touch screen with colour IPS display and 75° viewing angle.

Ethernet

Telemetry for easy assistance and remote updates.

Preset programs

Possibility of viewing and recording machining operations and dynamically setting the work program, choosing it from a library of preset programs.

Patented smart footswitch

The device performs all the functions of the traditional pedal and allows parameters adjustment by varying the pressure on the pedal, without interrupting the workflow.

★ PATENTED SYSTEM

TECHNICAL DATA

Evo X Tech

CRYSTAL TYPE	Nd:YAG @ 1064
PULSE POWER	250 J
PULSE DURATION	25 ms
PEAK PULSE POWER	10 kW
AVERAGE POWER	90 W
PULSE FREQUENCY	0 - 40 Hz
POWER SUPPLY	115 - 230 VAC ± 10%, 1P + N + PE, 50/60 Hz, 1.8 kW
FOCAL DIAMETER	0.1 to 2 mm
COMMAND ACCESS	External with 7" capacitive touch screen display, internal with rotary switch
COOLING SYSTEM	Liquid cooled (4 l) with forced ventilation
WEIGHT	41 kg

ACCESSORIES



DYNASCOPE HEAD



ADJUSTABLE MICROSCOPE STAND (5° - 25°)

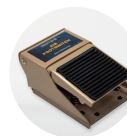

PNEUMATIC FOOTSWITCH



INTERNAL WRIST REST



ADJUSTABLE HEIGHT TABLE



WELDER PROTECTIVE COVER